

ZA-SK1050 Motherboard

User Manual

Support Intel® 6th/7th Corei7/Corei5/Corei3 Processor

Issue Date: 08/2018

ZA-SK1050 Motherboard Configuration Diagram

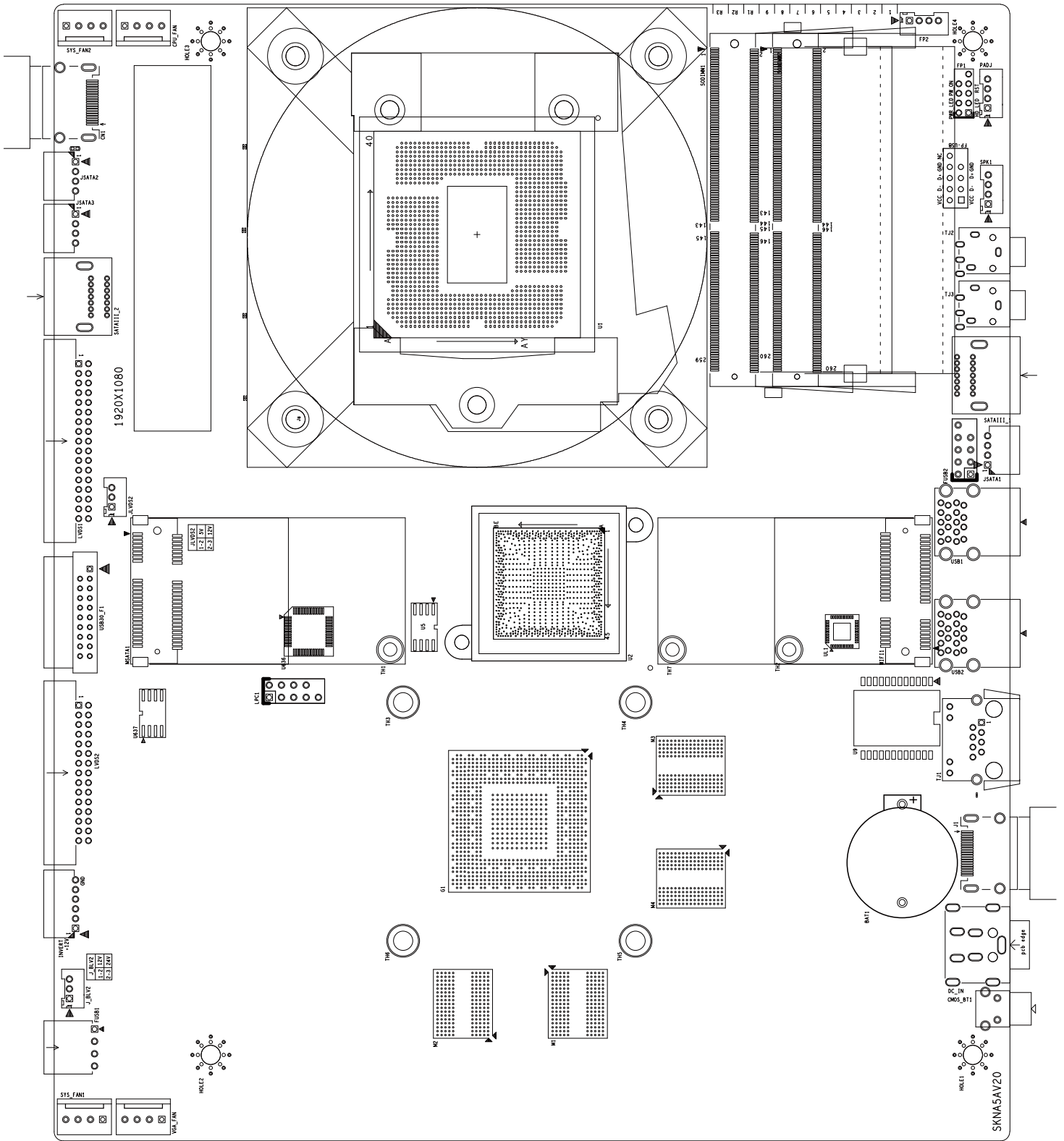

ZA-SK1050 Motherboard Diagram

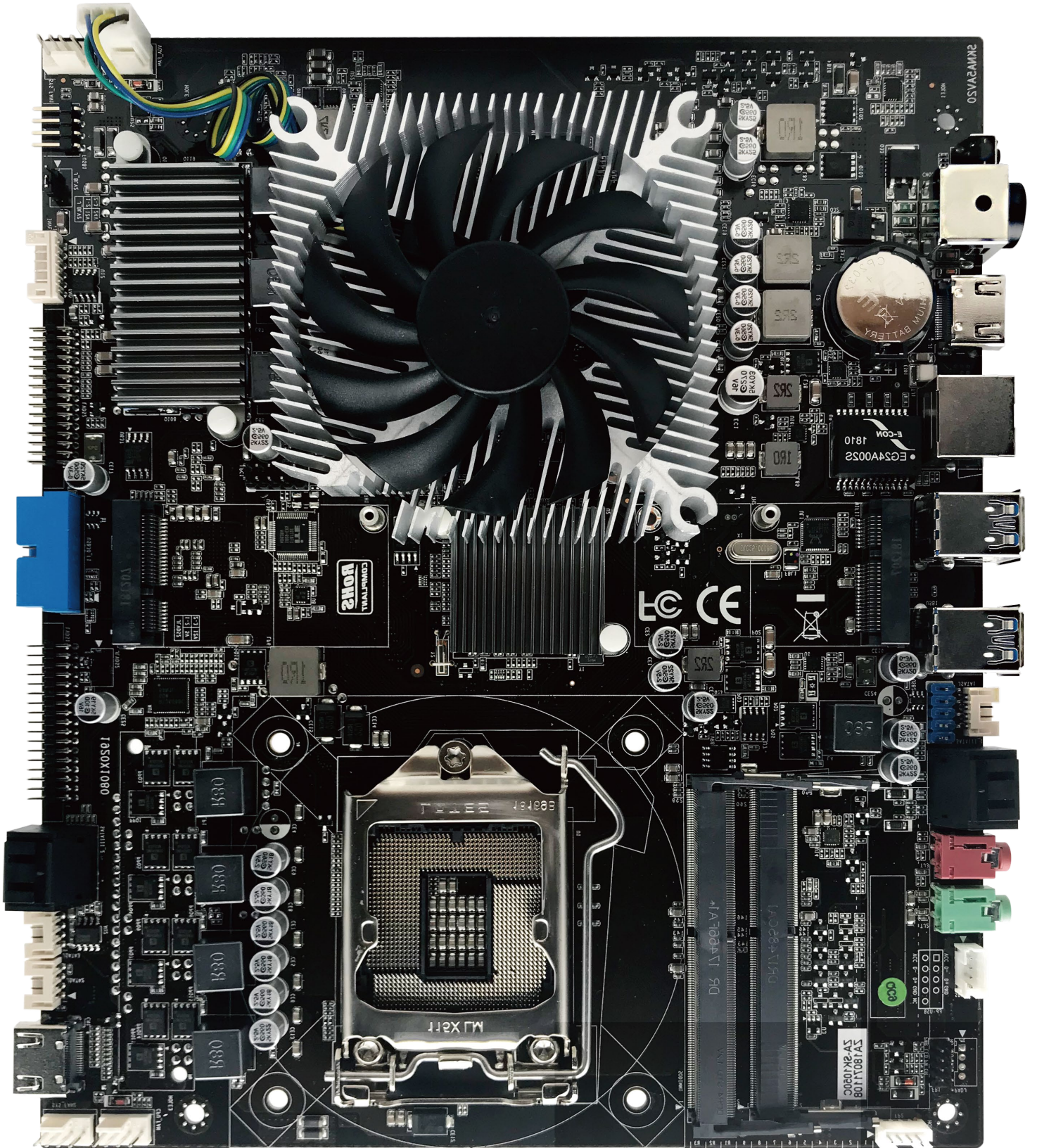

Motherboard Specification

Size	235mm x 197.5mm
CPU	Support Intel®6th/7th Core i7 i5 i3 Processor
Graphics	NVIDIA GTX1050(2G memory)
Chipset	B150
Memory	2*DDR4 2133MHZ,Up to 32GB
Internal I/O	2*USB2.0 Pin 3*USB Port 1*USB3.0 Pin 2*USB Port 1* CPU Fan And GPU Fan 2*SYS Fan 2*LVDS Pin(support dual Channel 10 Bit) 4*SATA 1*Front panel Pin 1*Audio Pin Port (2W/CH)
Rear I/O	1* DC Power Input (19V) 1*HDMI 1*LAN 4*USB3.0 1* Mic-in/Line-out
BIOS AMI	AMIBIOS,64M bit Flash Memory
MINI_PCIE	1*Support Msata 1*Support WiFi
SATA	4*SATA
LAN	1*Realtek 8111E,10/100/1000
Audio	ALC662 Dual Channel Output
Operating System	Windows7 Windows8 Windows10 Linux
H/W Monitoring	Walk in LAN System Power Management Temperature Management Voltage Management
Humidity	0% ~ 95% (Relative Humidity,No Condensation)
Temp	-10°C ~ 55°C

Motherboard I/O Interface Diagram

ZA-SK1050 Motherboard

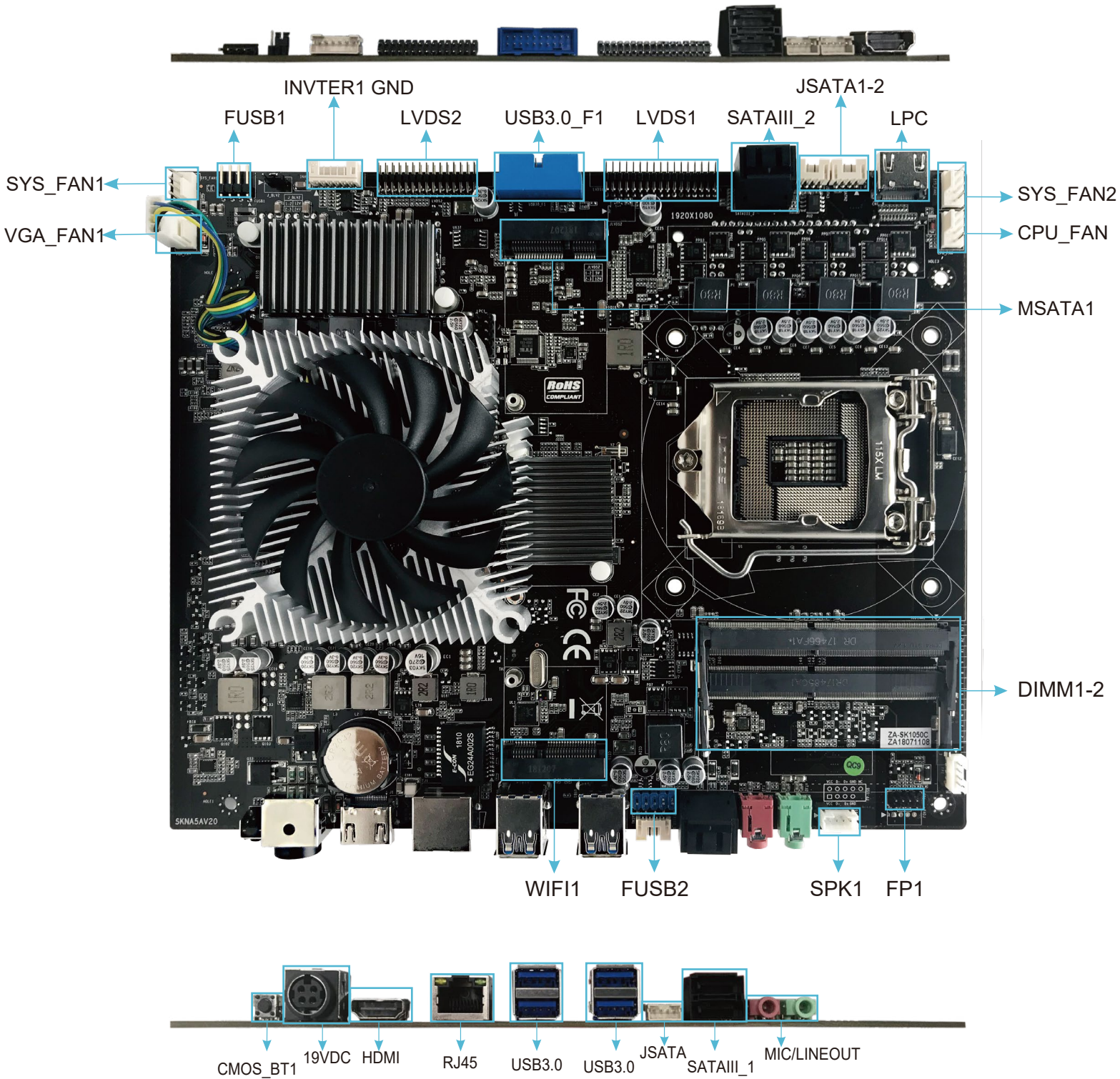

USB3.0_F1

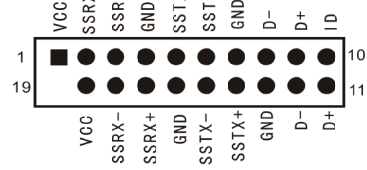

Pin	Define	Pin	Define
1	VCC	2	SSRX-
3	SSRS+	4	GND
5	SSTX-	6	SSTX+
7	GND	8	D-
9	D+	10	ID
11	D+	12	D-
13	GND	14	SSTX+
15	SSTX-	16	GND
17	SSRS+	18	SSRX-
19	VCC		

SATAIII_1
SATAIII_2

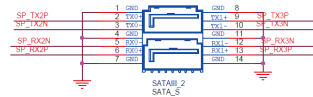
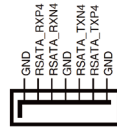

JSATA,JSATA1
JSATA2

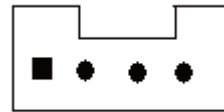

1 2 3 4
+5V 2. GND 3. GND 4. +12V

LPC

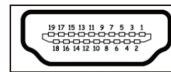

Note: this port belongs to the debugging port of the main board and cannot be used for other ports.

MSATA

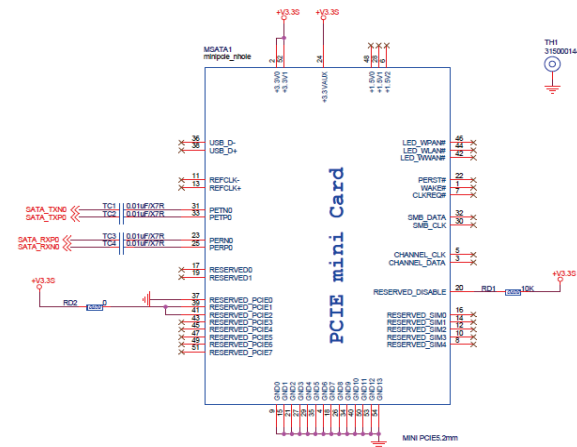

DIMM1 DIMM2

Installation memory:

1. Please turn off the power before installing or removing the memory, and dial down the AC power cord.
 2. Carefully hold both ends of the memory stick, and do not touch the metal contact above.
 3. Align the gold fingers of the memory stick with the memory stick slot, and pay attention to the convex point of the gold finger socket to the upper slot in the direction;
 4. Insert the memory stick 30 degrees into the memory slot, and then press the memory stick down to the sound of "click"
- The memory has been installed successfully and can be used (note: press down the memory bar to avoid damaging the memory too much)

Memory installation diagram (for reference only) :

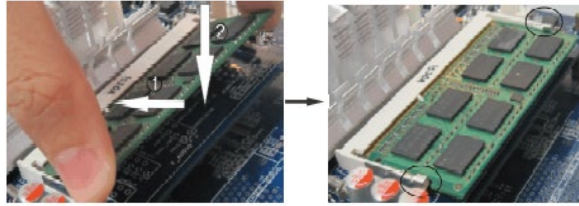

Note: static electricity damages electronic components of a computer or memory, so before following these steps, Be sure to touch the grounded metal objects briefly to remove static electricity from your body.

SPK1

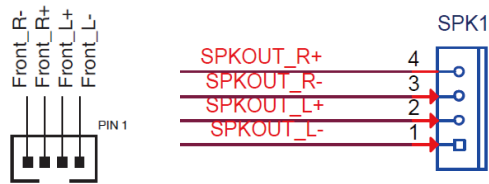

Pin	Define	Pin	Define
1	SPKOUT_L-	2	SPKOUT_L+
3	SPKOUT_R-	4	SPKOUT_R+

WIFI

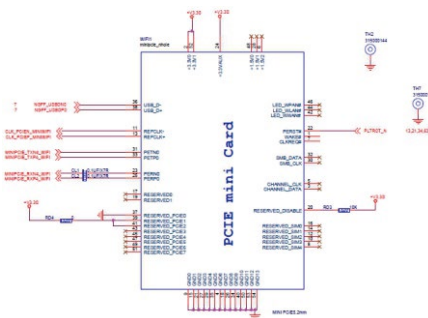

Note: when installing this card, please insert the card at an Angle of 30 degrees, then press down to the stud and fix it with screws.

CMOS_BT1



CMOS_BT1

19VDC

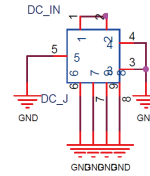
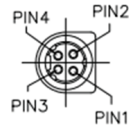

Pin	Define	Pin	Define
1	DC_IN	2	DC_J
3	GND	4	GND
5	GND	6	GND
7	GND	8	GND
9	GND		

HDMI



Pin	Define	Pin	Define
1	TMDS data 2+	2	TMDS data shield
3	TMDS data 2-	4	TMDS data 1+
5	TMDS data shield	6	TMDS data 2-
7	TMDS data 0+	8	TMDS data shield
9	TMDS data 0-	10	TMDS clock+
11	TMDS clock shield	12	TMDS clock-
13	CEC	14	No connectde
15	DDC clock	16	DDC data
17	Ground	18	+5V power
19	Hot plug detect		

RJ45

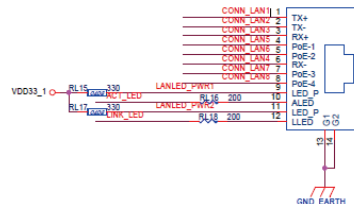

USB3.0
USB3.0

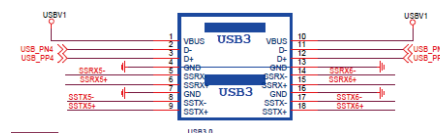

MICIN/LINEOUT																									
FP1	<table border="1" data-bbox="699 678 1353 1012"> <thead> <tr> <th>Pin</th> <th>Define</th> <th>Pin</th> <th>Define</th> </tr> </thead> <tbody> <tr> <td>1</td> <td>HDD LED+</td> <td>2</td> <td>PWR LED+</td> </tr> <tr> <td>3</td> <td>HDD LED-</td> <td>4</td> <td>GND</td> </tr> <tr> <td>5</td> <td>GND</td> <td>6</td> <td>P_SWIN</td> </tr> <tr> <td>7</td> <td>RESET_GND</td> <td>8</td> <td>GND</td> </tr> <tr> <td>9</td> <td>GND</td> <td></td> <td></td> </tr> </tbody> </table> <p data-bbox="726 1070 1316 1142"> HDD Active LED:1,3 Power Button:6,8 Power LED:2,4 Reset Button:5,7 </p>	Pin	Define	Pin	Define	1	HDD LED+	2	PWR LED+	3	HDD LED-	4	GND	5	GND	6	P_SWIN	7	RESET_GND	8	GND	9	GND		
Pin	Define	Pin	Define																						
1	HDD LED+	2	PWR LED+																						
3	HDD LED-	4	GND																						
5	GND	6	P_SWIN																						
7	RESET_GND	8	GND																						
9	GND																								

*Other Matters Please consult the sales.